

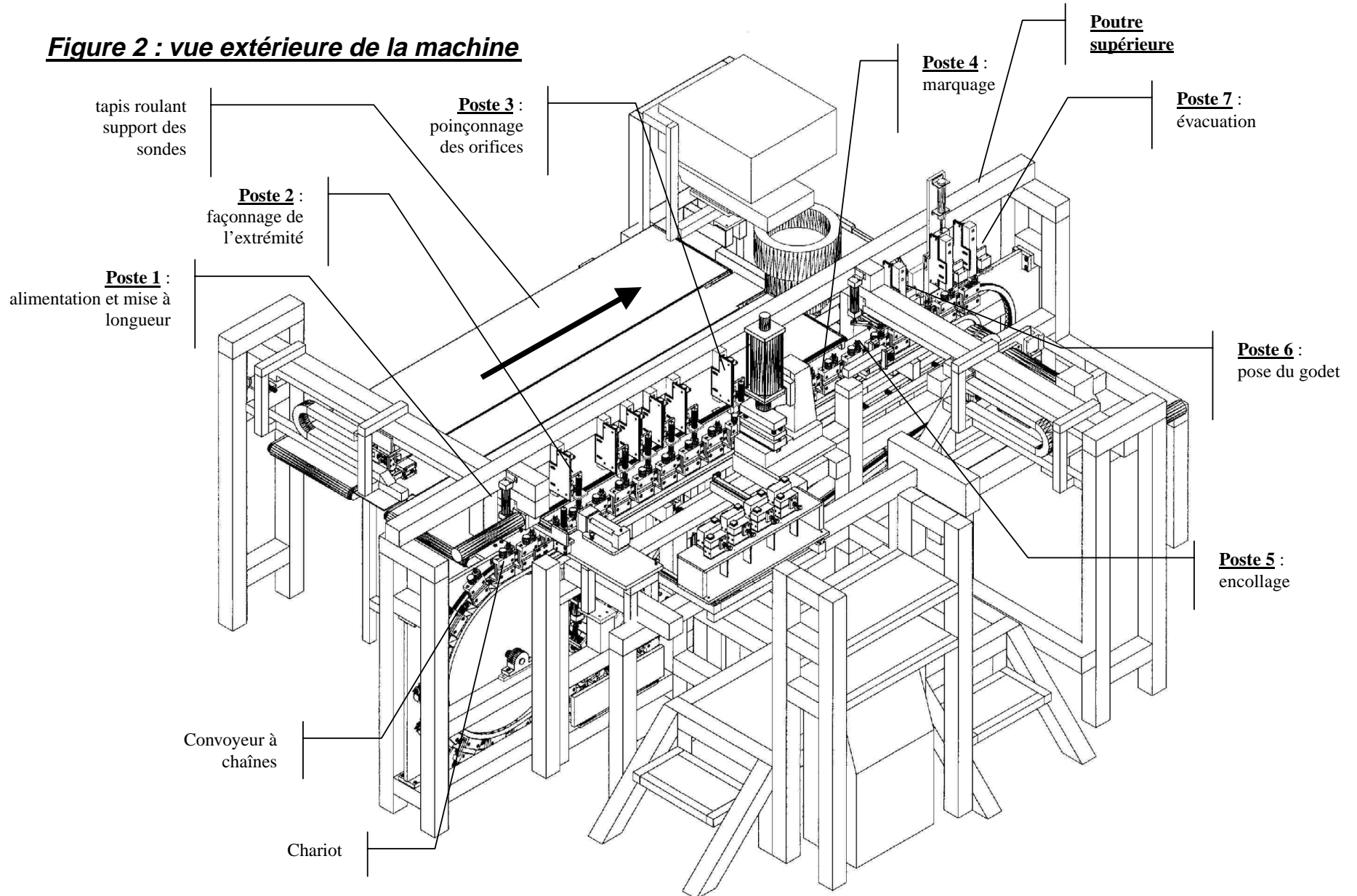
Figure 2 : vue extérieure de la machine

Figure 3 : convoyeur